

Strep A Rapid Test Device (CLIA Waived) Package Insert

A rapid test for the qualitative detection of Strep A antigen in throat swab specimens.

For professional *in vitro* diagnostic use only.

INTENDED USE

The Strep A Rapid Test Device (CLIA Waived) is a rapid chromatographic immunoassay for the qualitative detection of Strep A antigen from throat swab specimens to aid in the diagnosis of Group A Streptococcal infection.

SUMMARY

Streptococcus pyogenes is non-motile gram-positive cocci, which contains the Lancefield group A antigen that can cause serious infections such as pharyngitis, respiratory infection, impetigo, endocarditis, meningitis, puerperal sepsis, and arthritis.¹ Left untreated, these infections can lead to serious complications, including rheumatic fever and peritonsillar abscess.² Traditional identification procedures for Group A Streptococci infection involve the isolation and identification of viable organisms using techniques that require 24 to 48 hours or longer.³

The Strep A Rapid Test Device (CLIA Waived) is a rapid test to qualitatively detect the presence of Strep A antigen in throat swab specimens, providing results within 5 minutes. The test utilizes antibodies specific for whole cell Lancefield Group A Streptococcus to selectively detect Strep A antigen in a throat swab specimen.

PRINCIPLE

The Strep A Rapid Test Device (CLIA Waived) is a qualitative, lateral flow immunoassay for the detection of Strep A carbohydrate antigen in a throat swab. In this test, antibody specific to Strep A carbohydrate antigen is coated on the test line region of the device. During testing, the extracted throat swab specimen reacts with an antibody to Strep A that is coated onto particles. The mixture migrates up the membrane to react with the antibody to Strep A on the membrane and generate a red line in the test region. The presence of this red line in the test region indicates a positive result, while its absence indicates a negative result. To serve as a procedural control, a red line will always appear in the control region if the test has been performed properly. If a red control line does not appear, the test result is not valid.

KIT CONTENTS

- Test devices
- Sterile swabs
- Reagent A (2M Sodium Nitrite)
- Reagent B (0.4M Acetic Acid)
- Positive control (Non-viable Strep A; 0.1% NaN₃)
- Negative control (Non-viable Strep C; 0.1% NaN₃)
- Procedure card
- Package insert

Materials Required But Not Provided

- Timer

PRECAUTIONS

- For professional *in vitro* diagnostic use only. Do not use after expiration date.

- Do not eat, drink or smoke in the area where the specimens and kits are handled.
- Handle all specimens as if they contain infectious agents. Observe established precautions against microbiological hazards throughout the procedure and follow the standard procedures for proper disposal of specimens.
- Wear protective clothing such as laboratory coats, disposable gloves and eye protection when specimens are assayed.
- Humidity and temperature can adversely affect results.
- Reagent B contains an acidic solution. If the solution contacts the skin or eye, flush with large volumes of water.
- The positive and negative controls contain sodium azide (NaN₃) as a preservative.
- Do not interchange kit reagents.
- Do not interchange reagent bottle caps.
- Do not interchange external control solution bottle caps.
- Be careful not to topple the swab out of the extraction chamber during the extraction step. If the swab has been toppled, repeat the test.

STORAGE AND STABILITY

The kit can be stored at room temperature or refrigerated (2-30°C). The test device must remain in the sealed pouch until use. **DO NOT FREEZE**. The test device and the reagents are stable through the expiration date printed on the box. Do not use beyond the expiration date.

SPECIMEN COLLECTION AND PREPARATION

- Only use reagents provided in the kit.
- Collect the throat swab specimen with the sterile swab that is provided in the kit. Transport swabs containing modified Stuart's or Amies medium can also be used with this product. Swab the posterior pharynx, tonsils and other inflamed areas. Avoid touching the tongue, cheeks and teeth with the swab.⁵
- Testing should ideally be performed immediately after the specimens have been collected. Swab specimens may be stored in a clean, dry plastic tube for up to 8 hours at room temperature or 72 hours at 2°-8°C.
- If a culture is desired, lightly roll the swab tip onto a Group A selective blood agar plate before using the swab in the Strep A Rapid Test Device (CLIA Waived).

DIRECTIONS FOR USE

Allow the test device, reagents, and/or controls to reach room temperature (15°-30°C) before testing.

1. In order to obtain accurate results, the test should be performed immediately after opening the pouch. Remove the test device from the sealed foil pouch. The 2 Marks on top of the ribbed part of the valve should be positioned as shown in the image at right (**Closed Valve Position**). If they are not, turn the ribbed part of the valve to the left until it stops.
2. Hold the Reagent A bottle upright and add 5 full drops (approximately 300 µL) to the swab chamber. Reagent A is red in color. Hold the Reagent B bottle upright and add 5 full drops (approximately 200 µL) to the swab chamber. Reagent B is colorless.

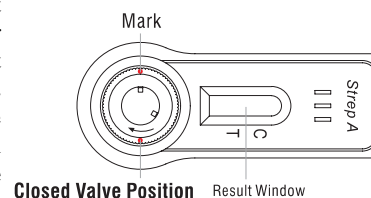

3. Immediately add the throat swab into the swab chamber. While holding the base of the chamber, agitate the swab vigorously 10 times in the swab chamber. Leave the swab in the chamber for 1 minute.
4. Remove the swab by holding down the swab chamber with the thumb and index finger. Lift the swab halfway up the chamber and press it against the ribs inside the wall of the chamber. Rotate the swab 5 times while pressing firmly against the ribs to release as much liquid as possible (see image at right). Discard the swab.
5. Open the valve by twisting the ribbed part of the valve to the right until it stops. The 2 Marks on top of the ribbed part of the valve should be aligned with the result window, as shown in the image at right (**Open Valve Position**). If the liquid has not appeared in the window in 1 minute after the valve is opened, discard the device and repeat the test with a new throat swab sample.
6. Set timer and read the result at 5 minutes.

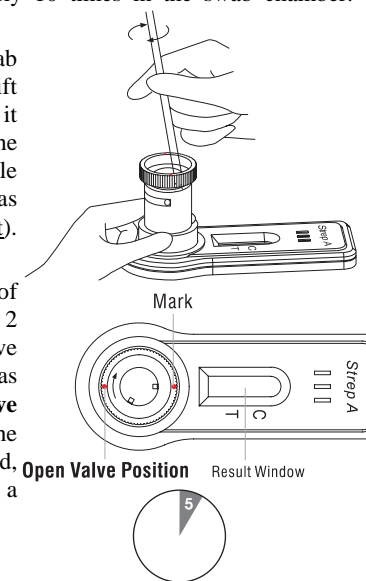

Note: Very low levels of Strep A might result in a weak line appearing in the test region after an extended period of time; therefore, do not read the result after 10 minutes.

INTERPRETATION OF RESULTS

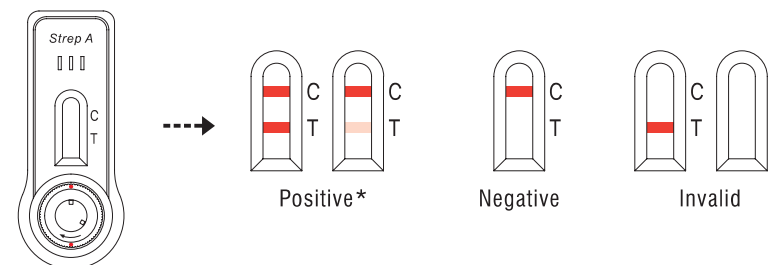

(Please refer to the illustration above)

POSITIVE*: Two distinct red lines appear. One line should be in the control region (C) and another line should be in the test region (T). A positive result indicates that Strep A was detected in the sample.

* **NOTE:** The shade of the red color in the test line region (T) will vary based on the amount of Strep A present in the sample. So any shade of red in the test region (T) should be considered positive.

NEGATIVE: One red line appears in the control region (C). No clear red or pink line appears in the test region (T). A negative result indicates that Strep A is not found in the sample, or is there but below the detection limit of the test. The patient's sample should be cultured to make sure that there is no Strep A infection. If the symptoms do not agree with the results, get another sample for culture.

INVALID: No line in the control region (C). If this occurs, read the direction again and repeat the test with a new test device. If the result is still invalid, stop using the test kit and contact your distributor.

QUALITY CONTROL

Internal Quality Control

Internal procedural controls are included in the test. A red line appearing in the control region (C) is an internal positive procedural control. It confirms sufficient specimen volume and correct procedural technique. A clear background is an internal negative procedural control. If the test is working properly, the background in the result area should be white to light pink and not interfere with the ability to read the test result.

External Quality Control

It is recommended that a positive and negative external control be run every 25 tests, and as deemed necessary by your internal laboratory procedures. External positive and negative controls are supplied in the kit. Alternatively, other Group A and non-Group A Streptococcus ATCC reference strains may be used as external controls. Some commercial controls may contain interfering preservatives; therefore, other commercial controls are not recommended.

Procedure for External Quality Control Testing

1. Add 5 full drops of Reagent A and 5 full drops of Reagent B into the swab chamber of a device, holding the bottles upright.
2. Add 1 full drop of positive or negative control solution into the swab chamber, holding the bottle upright.
3. Place a clean swab into the swab chamber. While holding the base of the chamber, agitate the swab vigorously 10 times in the swab chamber. Leave the swab in the chamber for 1 minute.
4. Continue with Step 4 of Directions For Use.

If the controls do not yield the expected results, do not use the test results. Repeat the test or contact your distributor.

LIMITATIONS

1. The Strep A Rapid Test Device (CLIA Waived) is for *in vitro* diagnostic use only. The test should be used for the detection of Strep A antigen in throat swab specimens only. Neither the quantitative value nor the rate of increase in Strep A antigen concentration can be determined by this qualitative test.
2. This test will only indicate the presence of Strep A antigen in the specimen from both viable and non-viable Group A Streptococcus bacteria.
3. A negative result obtained from this kit should be confirmed by culture. A negative result may be obtained if the concentration of the Strep A antigen present in the throat swab is not adequate or is below the detectable level of the test.
4. Excess blood or mucus on the swab specimen may interfere with test performance and may yield a false positive result. Avoid touching the tongue, cheeks, and teeth⁵ and any bleeding areas of the mouth with the swab when collecting specimens.
5. As with all diagnostic tests, all results must be interpreted together with other clinical information available to the physician.

EXPECTED VALUES

Approximately 15% of pharyngitis in children ages 3 months to 5 years is caused by Group A beta-hemolytic Streptococcus.⁶ In school-aged children and adults, the incidence of Strep throat infection is about 40%.⁷ This disease usually occurs in the winter and early spring in temperate climates.³

PERFORMANCE CHARACTERISTICS

Using three medical centers and a reference laboratory for evaluation, a total of 758 throat swabs were collected from patients exhibiting symptoms of pharyngitis. Each swab was rolled onto a Group A selective blood agar plate, and then tested by the Strep A Rapid Test Device (CLIA Waived). The plates were further streaked for isolation, and then incubated at 37°C with 5-10% CO₂ and a Bacitracin disk for 18-24 hours. The negative culture plates were incubated for an additional 18-24 hours. Possible GAS colonies were subcultured and confirmed with a commercially available latex agglutination grouping kit.

Of the 758 total specimens, 492 were found to be negative by culture and 266 were found to be positive by culture. Two out of the 758 specimens yielded invalid results and are therefore excluded from the table.

Pediatric Population:

		Culture	
		+	-
Strep A Test	+	231	26
Device	-	23	416

Sensitivity: 231/254 = 91% (87%-94%)*

Specificity: 416/442 = 94% (91%-96%)*

Accuracy: 647/696 = 93% (91%-95%)*

Adult Population:

		Culture	
		+	-
Strep A Test	+	9	1
Device	-	2	48

Sensitivity: 9/11 = 82% (48%-98%)*

Specificity: 48/49 = 98% (89%-100%)*

Accuracy: 57/60 = 95% (86%-99%)*

Combined Population:

		Culture	
		+	-
Strep A Test	+	240	27
Device	-	25	464

Sensitivity: 240/265 = 90% (86% - 94%)*

Specificity: 464/491 = 94% (92% - 96%)*

Accuracy: 704/756 = 93% (91% - 95%)*

* Denotes a 95% Confidence Interval

Positive Culture Classification	Strep A Test Device/ Culture	% Correct
Rare	6/11	54
1+	16/20	80
2+	17/23	74
3+	26/29	90
4+	175/182	96

Cross-Reactivity

The following organisms were tested at 1.0 x 10⁷ organisms per test and were all found to be negative when tested with the Strep A Rapid Test Device (CLIA Waived).

<i>Bordetella pertussis</i>	<i>Neisseria sicca</i>
<i>Branhamella catarrhalis</i>	<i>Neisseria subflava</i>
<i>Candida albicans</i>	<i>Pseudomonas aeruginosa</i>
<i>Corynebacterium diphtheriae</i>	<i>Serratia marcescens</i>
<i>Enterococcus faecalis</i>	<i>Staphylococcus aureus</i>
<i>Escherichia coli</i>	<i>Staphylococcus epidermidis</i>
<i>Group B Streptococcus</i>	<i>Streptococcus anginosus</i>
<i>Group C Streptococcus</i>	<i>Streptococcus intermedius</i>
<i>Group F Streptococcus</i>	<i>Streptococcus mitis</i>
<i>Group G Streptococcus</i>	<i>Streptococcus mutans</i>
<i>Hemophilus influenzae</i>	<i>Streptococcus oralis</i>
<i>Klebsiella pneumoniae</i>	<i>Streptococcus pneumoniae</i>
<i>Neisseria gonorrhoea</i>	<i>Streptococcus sanguinis</i>
<i>Neisseria meningitidis</i>	

POL Studies

Three physicians' offices were used to conduct an evaluation of the Strep A Rapid Test Device (CLIA Waived). Personnel with various educational backgrounds performed the testing. Each physician's office tested a randomly coded panel of samples consisting of negative (20), low positive (20), and medium positive (20) for three days. The results obtained had a 99% correlation with the expected results.

BIBLIOGRAPHY

1. Manual of Clinical Microbiology, 6th Edition, ASM Press, p. 299-307, 1995.
2. Webb, KH. *Pediatrics* (Feb 1998), 101:2, 2.
3. Bisno AL, Gerber MA, Gwaltney JM, Kaplan EL, Schwartz RH. *Clinical Infectious Diseases* (1997), 25, 574-83.
4. Needham CA, McPherson KA, Webb KH. *Journal of Clinical Microbiology* (Dec 1998), 3468-3473.
5. Shea, Y.R., Specimen Collection and Transport, in *Clinical Microbiology Procedures Handbook*, Isenberg, H.D., American Society of Microbiology, Washington, D.C., 1.1.1-1.1.30, 1992.
6. Nussinovitch, M, Finkelstein Y, Amir J, Varsano, I. *Clinical Pediatrics* (June 1999), 357-360.
7. Woods WA, Carter CT, Stack M, Connors Jr AF, Schlager TA, *Southern Medical Journal* (May 1999), 491-492.

Patent No. US 6,565,808

CLIA Category

WAIVED

